

IMPORTANT



WIRING CONNECTION & INSTALLATION BEST PRACTICES



KEEP MODULES AWAY FROM HEAT SOURCES



MOUNT WITH LOGO FACING UP AND/OR OUT TO A SIDE

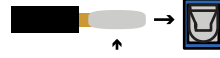

SOLDER WIRE TIPS BEFORE SECURING TO TERMINALS



TERMINALS SHOULD BE SNUG AND NOT OVER-TIGHTENED



PINOUTS AND DIMENSIONS

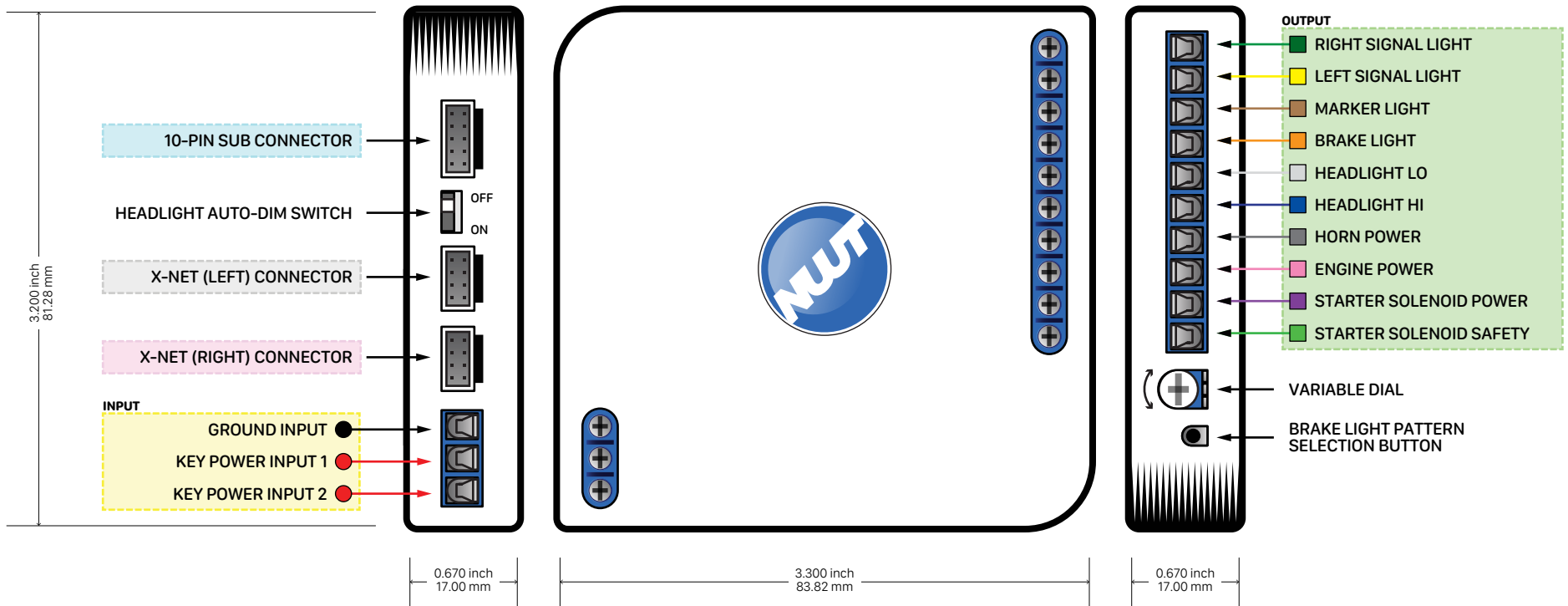

FOR CLARIFICATION AND ASSISTANCE TO YOUR SPECIFIC APPLICATION, OUR ENGINEERING TEAM WOULD BE GLAD TO ANSWER ALL YOUR QUESTIONS. NWTCYCLETRONIC.COM



IMPORTANT**WIRING CONNECTION & INSTALLATION BEST PRACTICES**

KEEP MODULES AWAY FROM HEAT SOURCES



MOUNT WITH LOGO FACING UP AND/OR OUT TO A SIDE

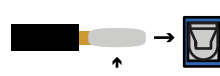

SOLDER WIRE TIPS BEFORE SECURING TO TERMINALS

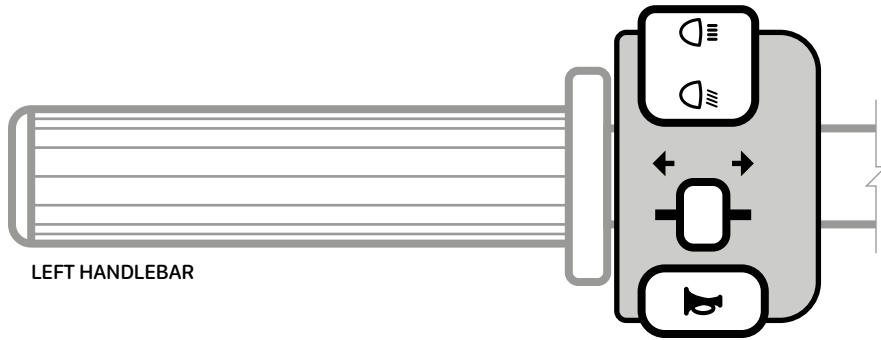

TERMINALS SHOULD BE SNUG AND NOT OVER-TIGHTENED

**SPECIAL BUTTON/SWITCH FUNCTIONS**

LEFT HANDLEBAR

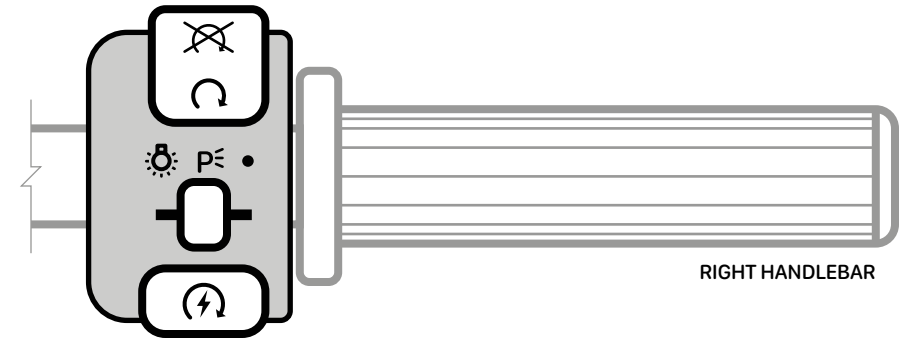

RIGHT HANDLEBAR

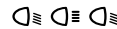
AUTOMATED FLASH-TO-PASS
Quickly toggle the Headlight HI/LO switch***HAZARD LIGHTS LEFT HAND DRIVE MODEL***
Activate RIGHT TURN SIGNAL, then push HORN BUTTON 3 times***HAZARD LIGHTS RIGHT HAND DRIVE MODEL***
Activate LEFT TURN SIGNAL, then push HORN BUTTON 3 times**TURN SIGNAL LIGHT FLASH PATTERN SELECTION**
Quickly push HORN BUTTON 4 times to select next pattern

- PATTERN
- 1 - single burst (default)
 - 2 - double burst
 - 3 - single, then double burst
 - 4 - variable blink speed using VARIABLE DIAL on MODULE side
 - 5 - single sequential (sequential lights required)
 - 6 - half, then full sequential (sequential lights required)

ENGINE ON + NEUTRAL ON CLUTCH ON + **ENGINE START**

Hold down START BUTTON

Engine switch must be in ON POSITION + NEUTRAL or CLUTCH switch ON

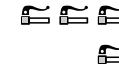
**BRAKE LIGHT AUTO HOLD**Activate by quickly pulsing the BRAKE LEVER/PEDAL 3 times
Once to deactivate.**BRAKE LIGHT FLASH PATTERN SELECTION (MODULE SIDE)**

Press BUTTON on the side of the module to select next pattern

- PATTERN
- 1 - standard (default)
 - 2 - 4 flashes
 - 3 - 2 flashes

FOR CLARIFICATION AND ASSISTANCE TO YOUR SPECIFIC APPLICATION, OUR ENGINEERING TEAM WOULD BE GLAD TO ANSWER ALL YOUR QUESTIONS. NWTCYCLETRONIC.COM

IMPORTANT

WIRING CONNECTION & INSTALLATION BEST PRACTICES



KEEP MODULES AWAY FROM HEAT SOURCES



BEST



GOOD



WORST

MOUNT WITH LOGO FACING UP AND/OR OUT TO A SIDE

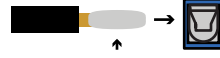

SOLDER WIRE TIPS BEFORE SECURING TO TERMINALS



TERMINALS SHOULD BE SNUG AND NOT OVER-TIGHTENED



INPUT

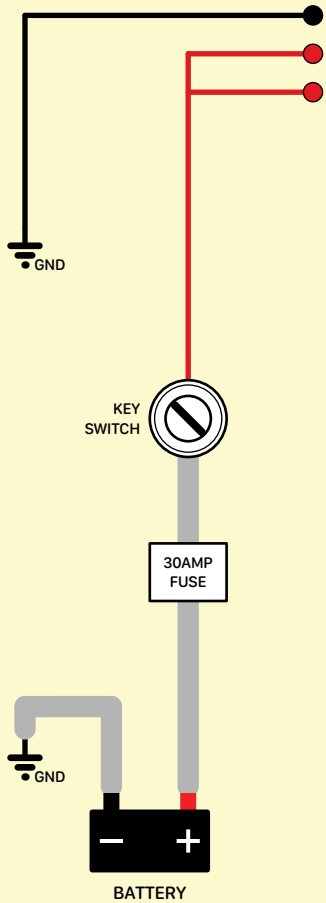

X-NET (LEFT)

X-NET (L) CONNECTOR

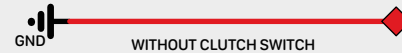
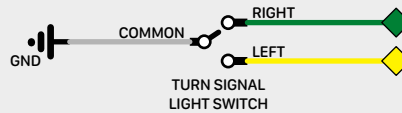
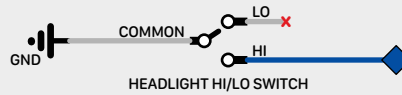

X-NET (RIGHT)

X-NET (R) CONNECTOR

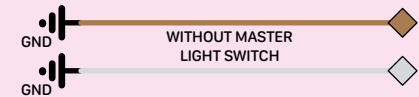
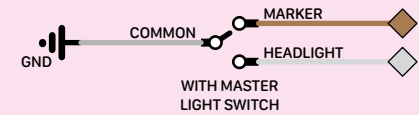
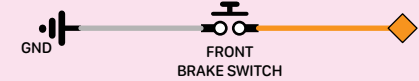
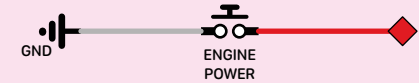

FOR CLARIFICATION AND ASSISTANCE TO YOUR SPECIFIC APPLICATION, OUR ENGINEERING TEAM WOULD BE GLAD TO ANSWER ALL YOUR QUESTIONS. NWTCYCLETRONIC.COM



IMPORTANT



WIRING CONNECTION & INSTALLATION BEST PRACTICES



KEEP MODULES AWAY FROM HEAT SOURCES



MOUNT WITH LOGO FACING UP AND/OR OUT TO A SIDE

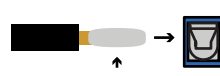

SOLDER WIRE TIPS BEFORE SECURING TO TERMINALS



TERMINALS SHOULD BE SNUG AND NOT OVER-TIGHTENED



10-PIN SUB CONNECTOR

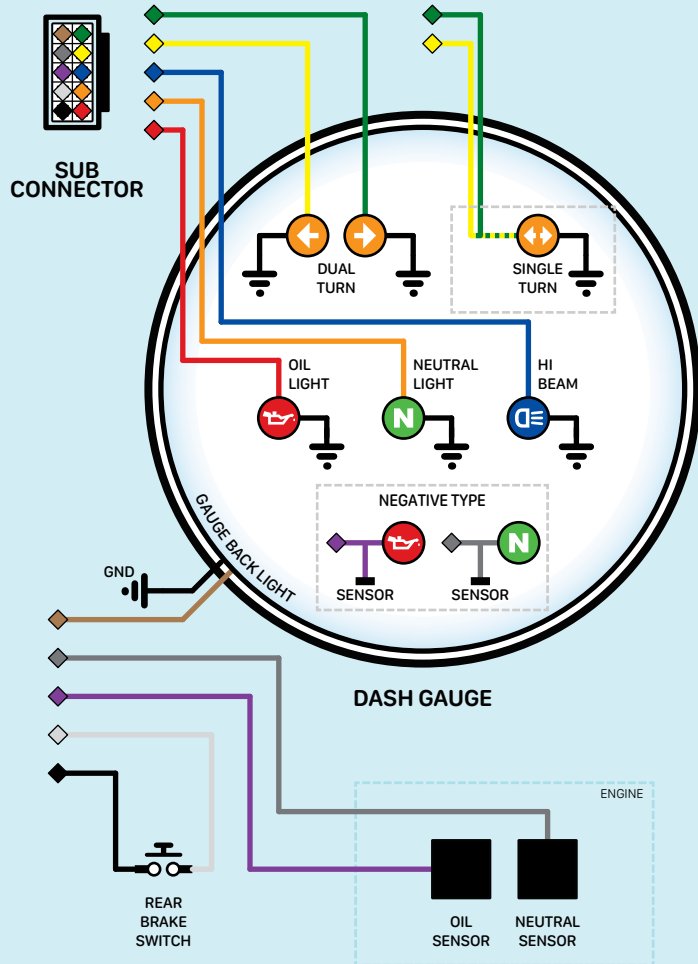

OUTPUT

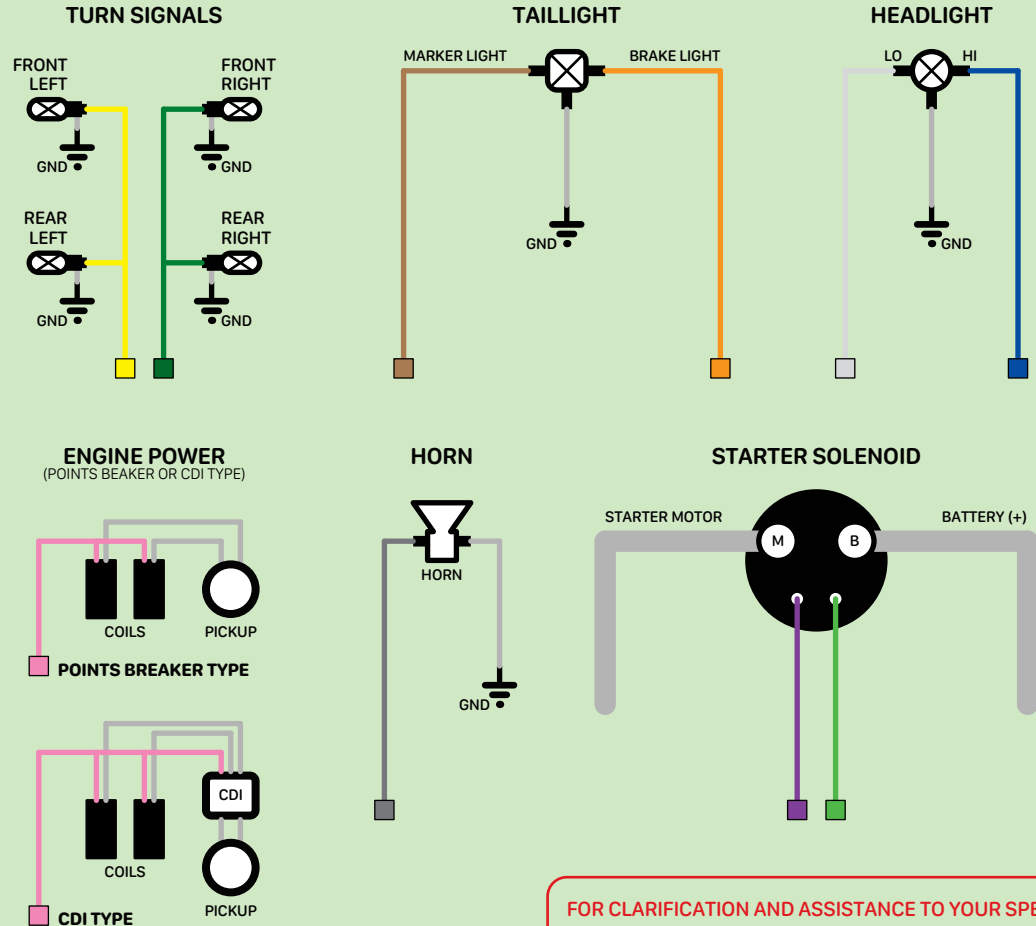

FOR CLARIFICATION AND ASSISTANCE TO YOUR SPECIFIC APPLICATION, OUR ENGINEERING TEAM WOULD BE GLAD TO ANSWER ALL YOUR QUESTIONS. NWTCYCLETRONIC.COM

