

# X3.P

## Specific Installation CX/GL 500 (CDI)

AUXILIARY  
FOR USAGE AND OPTIONS, CONTACT  
TECHSERVICE@NWT CYCLETRONIC.COM

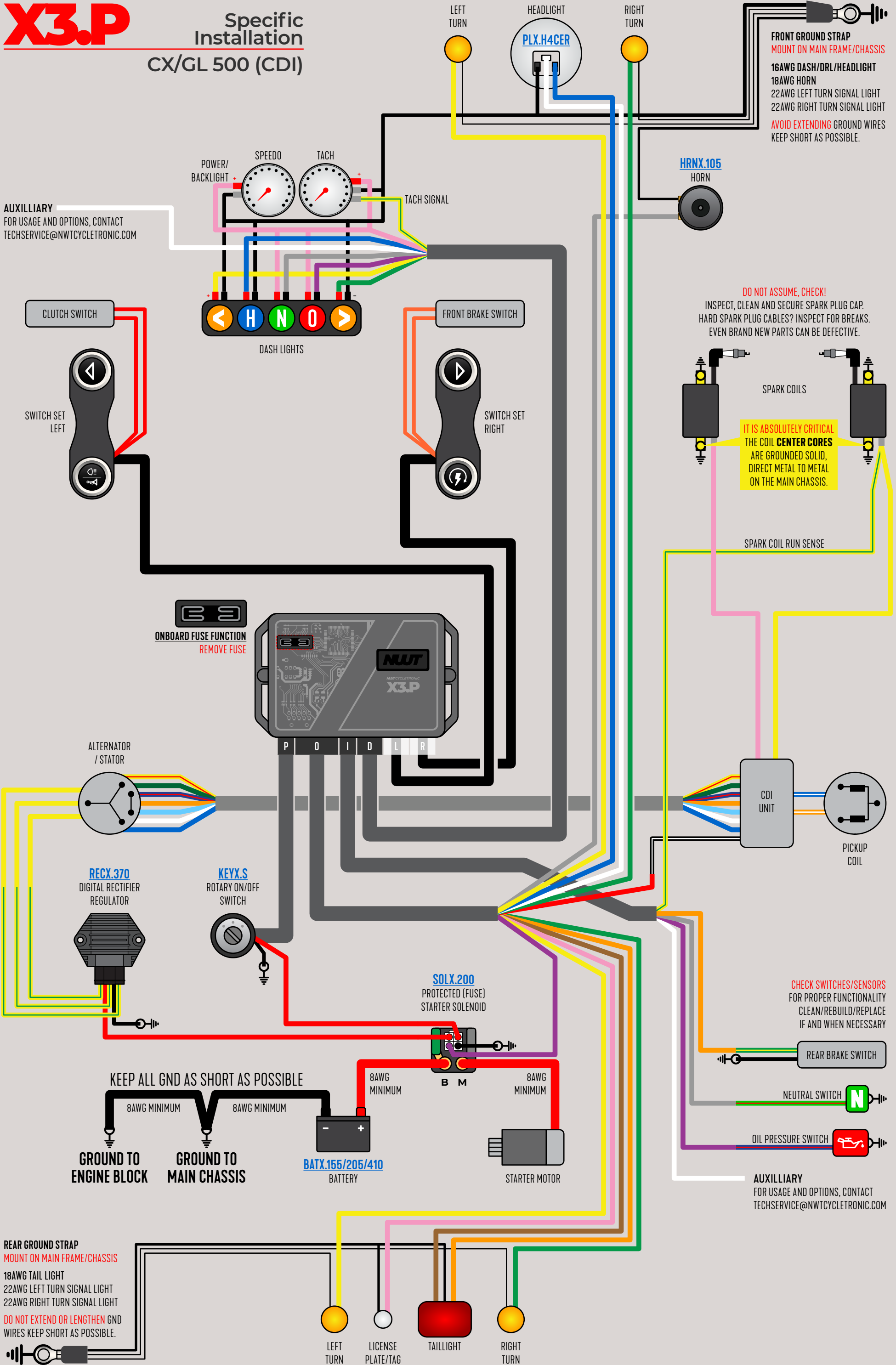

**FRONT GROUND STRAP**  
MOUNT ON MAIN FRAME/CHASSIS  
16AWG DASH/DRL/HEADLIGHT  
18AWG HORN  
22AWG LEFT TURN SIGNAL LIGHT  
22AWG RIGHT TURN SIGNAL LIGHT  
AVOID EXTENDING GROUND WIRES  
KEEP SHORT AS POSSIBLE.

**DO NOT ASSUME, CHECK!**  
INSPECT, CLEAN AND SECURE SPARK PLUG CAP.  
HARD SPARK PLUG CABLES? INSPECT FOR BREAKS.  
EVEN BRAND NEW PARTS CAN BE DEFECTIVE.

**IT IS ABSOLUTELY CRITICAL**  
THE COIL **CENTER CORES**  
ARE GROUNDED SOLID,  
DIRECT METAL TO METAL  
ON THE MAIN CHASSIS.

**CHECK SWITCHES/SENSORS**  
FOR PROPER FUNCTIONALITY  
CLEAN/REBUILD/REPLACE  
IF AND WHEN NECESSARY

**KEEP ALL GND AS SHORT AS POSSIBLE**  
8AWG MINIMUM  
GROUND TO ENGINE BLOCK  
GROUND TO MAIN CHASSIS  
BATTERY: BATX.155/205/410

**REAR GROUND STRAP**  
MOUNT ON MAIN FRAME/CHASSIS  
18AWG TAIL LIGHT  
22AWG LEFT TURN SIGNAL LIGHT  
22AWG RIGHT TURN SIGNAL LIGHT  
DO NOT EXTEND OR LENGTHEN GND  
WIRES KEEP SHORT AS POSSIBLE.

AUXILIARY  
FOR USAGE AND OPTIONS, CONTACT  
TECHSERVICE@NWT CYCLETRONIC.COM