

# TC3.S

## Specific Installation

### KZ 650

(with CDI + 3P Magnet Stator)

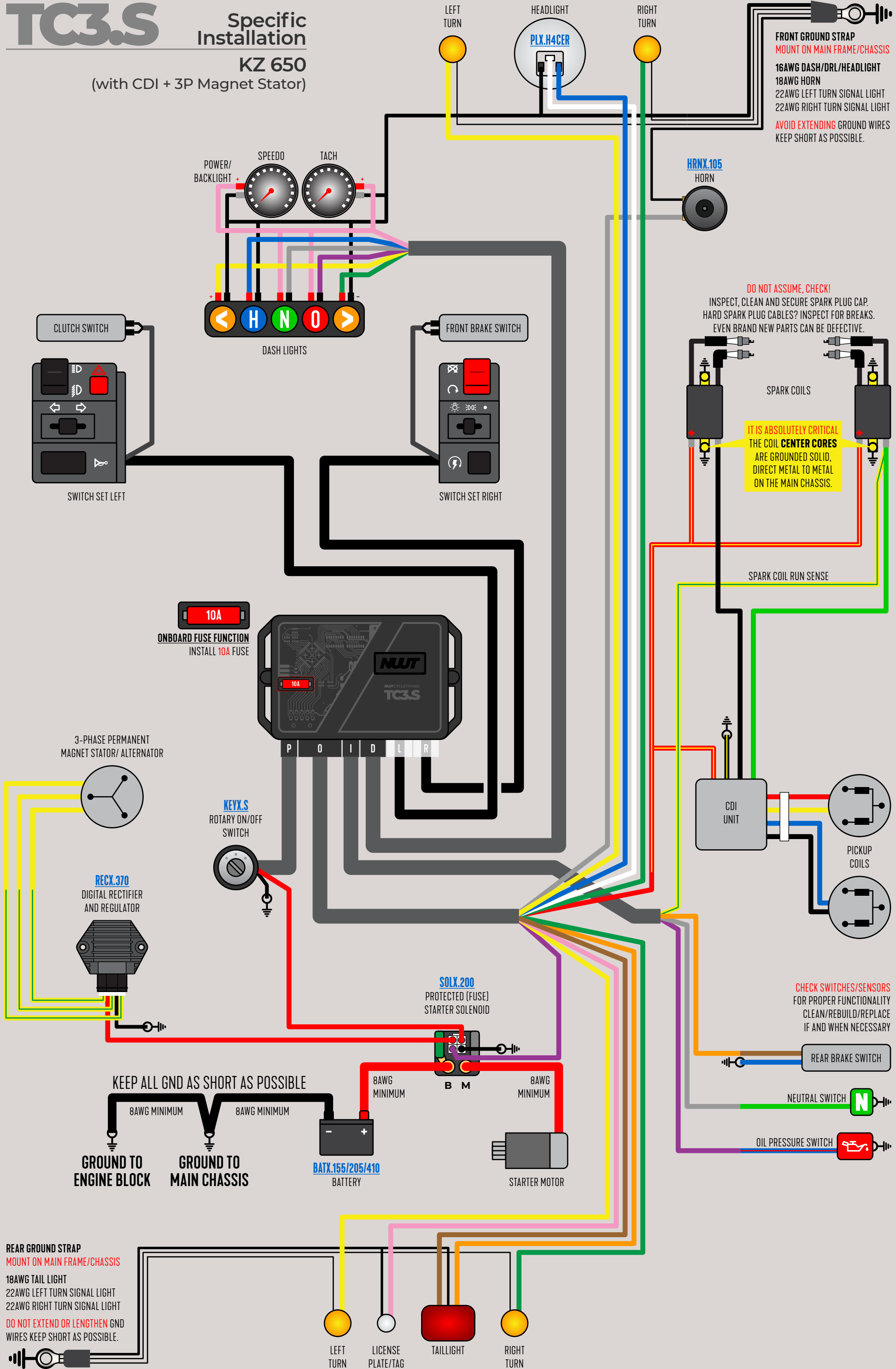

**FRONT GROUND STRAP**  
 MOUNT ON MAIN FRAME/CHASSIS  
 16AWG DASH/DRL/HEADLIGHT  
 18AWG HORN  
 22AWG LEFT TURN SIGNAL LIGHT  
 22AWG RIGHT TURN SIGNAL LIGHT  
 AVOID EXTENDING GROUND WIRES  
 KEEP SHORT AS POSSIBLE.

**DO NOT ASSUME, CHECK!**  
 INSPECT, CLEAN AND SECURE SPARK PLUG CAP.  
 HARD SPARK PLUG CABLES? INSPECT FOR BREAKS.  
 EVEN BRAND NEW PARTS CAN BE DEFECTIVE.

**IT IS ABSOLUTELY CRITICAL**  
 THE COIL **CENTER CORES**  
 ARE GROUNDED SOLID,  
 DIRECT METAL TO METAL  
 ON THE MAIN CHASSIS.

**CHECK SWITCHES/SENSORS**  
 FOR PROPER FUNCTIONALITY  
 CLEAN/REBUILD/REPLACE  
 IF AND WHEN NECESSARY

**KEEP ALL GND AS SHORT AS POSSIBLE**  
 8AWG MINIMUM  
 8AWG MINIMUM  
 8AWG MINIMUM  
**BATTERY**  
 BATX.155/205/410  
**STARTER MOTOR**

**REAR GROUND STRAP**  
 MOUNT ON MAIN FRAME/CHASSIS  
 18AWG TAIL LIGHT  
 22AWG LEFT TURN SIGNAL LIGHT  
 22AWG RIGHT TURN SIGNAL LIGHT  
 DO NOT EXTEND OR LENGTHEN GND  
 WIRES KEEP SHORT AS POSSIBLE.