

X3.S

Specific Installation KZ 440 (CDI)

AUXILIARY
FOR USAGE AND OPTIONS, CONTACT
TECHSERVICE@NWT CYCLETRONIC.COM

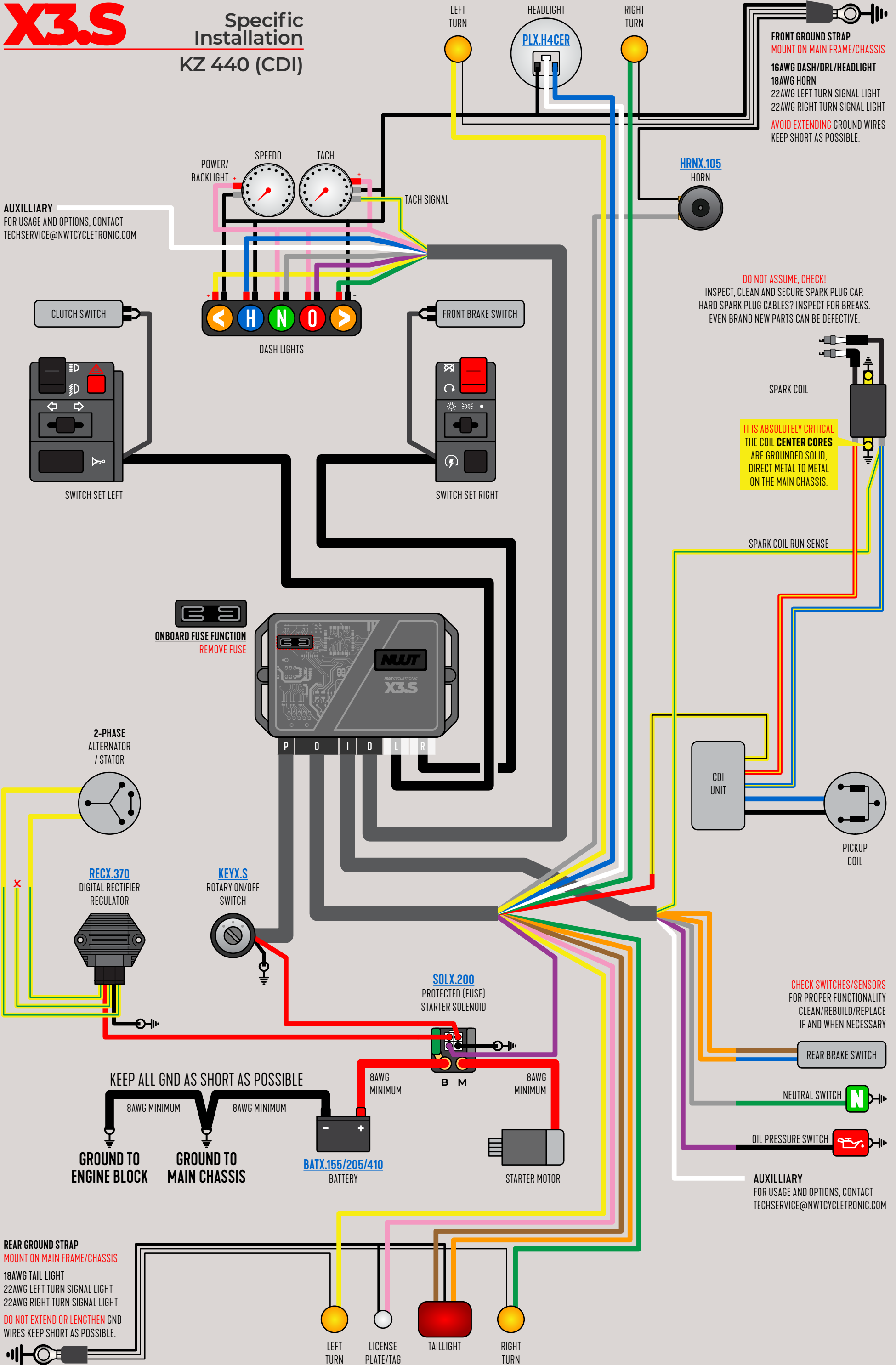

FRONT GROUND STRAP
MOUNT ON MAIN FRAME/CHASSIS
16AWG DASH/DRL/HEADLIGHT
18AWG HORN
22AWG LEFT TURN SIGNAL LIGHT
22AWG RIGHT TURN SIGNAL LIGHT
AVOID EXTENDING GROUND WIRES
KEEP SHORT AS POSSIBLE.

DO NOT ASSUME, CHECK!
INSPECT, CLEAN AND SECURE SPARK PLUG CAP.
HARD SPARK PLUG CABLES? INSPECT FOR BREAKS.
EVEN BRAND NEW PARTS CAN BE DEFECTIVE.

IT IS ABSOLUTELY CRITICAL
THE COIL **CENTER CORES**
ARE GROUNDED SOLID,
DIRECT METAL TO METAL
ON THE MAIN CHASSIS.

CHECK SWITCHES/SENSORS
FOR PROPER FUNCTIONALITY
CLEAN/REBUILD/REPLACE
IF AND WHEN NECESSARY

KEEP ALL GND AS SHORT AS POSSIBLE
8AWG MINIMUM
8AWG MINIMUM
8AWG MINIMUM
GROUND TO ENGINE BLOCK
GROUND TO MAIN CHASSIS
BATX.155/205/410
BATTERY

REAR GROUND STRAP
MOUNT ON MAIN FRAME/CHASSIS
18AWG TAIL LIGHT
22AWG LEFT TURN SIGNAL LIGHT
22AWG RIGHT TURN SIGNAL LIGHT
DO NOT EXTEND OR LENGTHEN GND
WIRES KEEP SHORT AS POSSIBLE.