

X3.S

Specific Installation

KZ 650

(with Points Breaker + 2P Magnet Stator)

AUXILIARY
FOR USAGE AND OPTIONS, CONTACT
TECHSERVICE@NWT CYCLETRONIC.COM

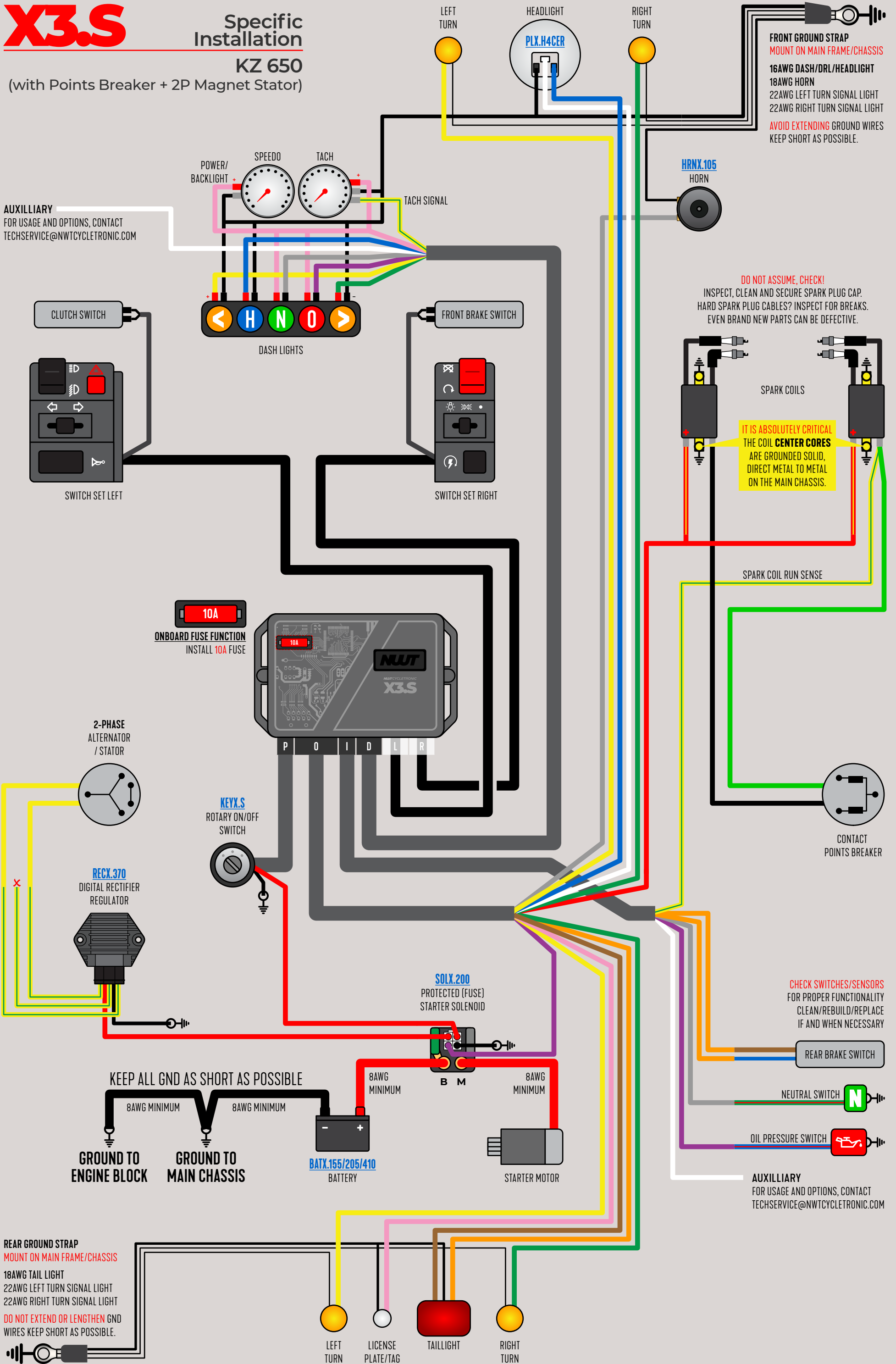

FRONT GROUND STRAP
MOUNT ON MAIN FRAME/CHASSIS

- 16AWG DASH/DRL/HEADLIGHT
- 18AWG HORN
- 22AWG LEFT TURN SIGNAL LIGHT
- 22AWG RIGHT TURN SIGNAL LIGHT

AVOID EXTENDING GROUND WIRES
KEEP SHORT AS POSSIBLE.

DO NOT ASSUME, CHECK!
INSPECT, CLEAN AND SECURE SPARK PLUG CAP.
HARD SPARK PLUG CABLES? INSPECT FOR BREAKS.
EVEN BRAND NEW PARTS CAN BE DEFECTIVE.

IT IS ABSOLUTELY CRITICAL
THE COIL **CENTER CORES**
ARE GROUNDED SOLID,
DIRECT METAL TO METAL
ON THE MAIN CHASSIS.

CHECK SWITCHES/SENSORS
FOR PROPER FUNCTIONALITY
CLEAN/REBUILD/REPLACE
IF AND WHEN NECESSARY

REAR GROUND STRAP
MOUNT ON MAIN FRAME/CHASSIS

- 18AWG TAIL LIGHT
- 22AWG LEFT TURN SIGNAL LIGHT
- 22AWG RIGHT TURN SIGNAL LIGHT

DO NOT EXTEND OR LENGTHEN GND
WIRES KEEP SHORT AS POSSIBLE.