

# TC3.M Control Hub

## MULTIPLEX SWITCH

**FEATURES**

- Complete electrical control hub
- Atmel 8-bit AVR® RISC-based microcontroller
- Trench type MOSFET powered
- Solid State design for water-proof and shock-proof operation
- 4 layer PCB design utilizing SMD components
- PTC smart fuse protection with auto reset
- Optimized for LED lighting
- On board "fly-back" protection circuit
- AC/DC voltage runaway engine shutdown protection
- Enhanced engine power protection with quick blow fuse
- Complete color-coded wiring harness
- No start ignition coil time-out power off
- Starter motor safety lock out with anti-grind
- Starter motor max crank time out
- Brake light flash pre-warning
- Onboard digital flasher
- Intelligent directional switching signal light
- "PARK" position light feature (Brake light)
- Master light control
- Sensor inputs
- Dash gauge outputs (Standard)
- Soft start headlight ON
- Engine run monitoring
- Multi-use internally protected power output
- DIY fully configurable handlebar switch input
- Handlebar switch size/type (DIY)
- 1 year replacement warranty & tech service

**INCLUDES**

- TC3.M Control Hub
- Plug in wiring harness (Power, Output, Input, Dash)
- Plug&Go handlebar switch set harness  
(for DIY handlebar switches)
- GND harness

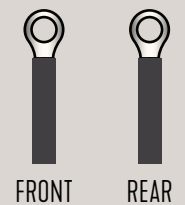
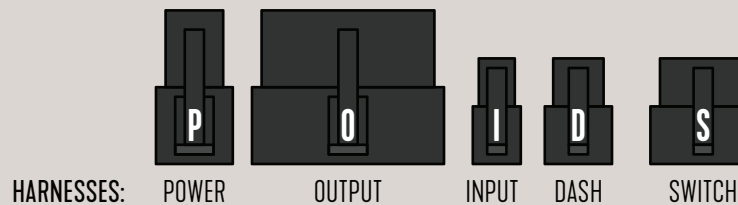
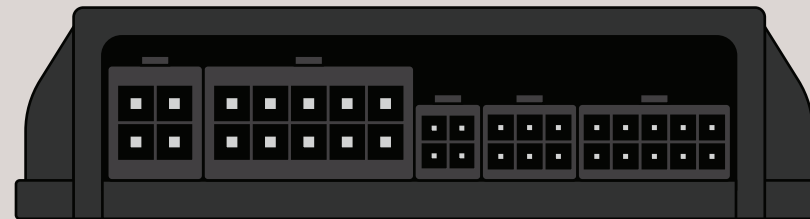
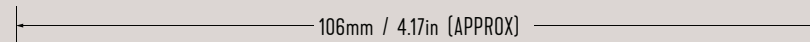
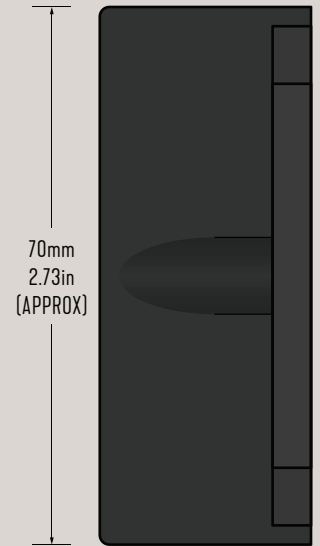
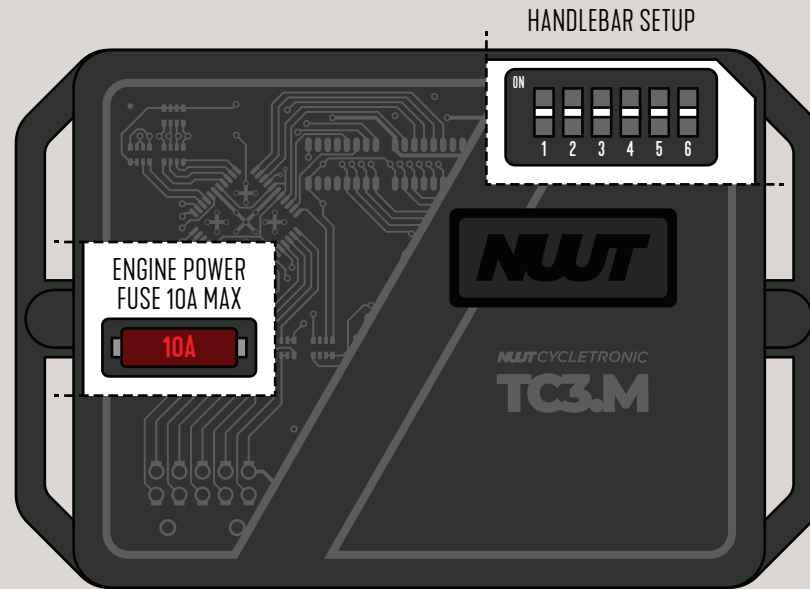

MAIN CHASSIS  
GROUND STRAPS

# TC3.M Pinouts

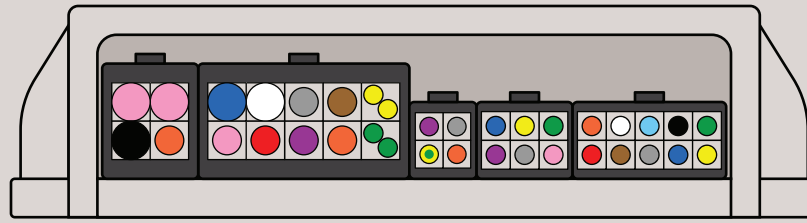

POWER      OUTPUT      INPUT      DASH      SWITCH

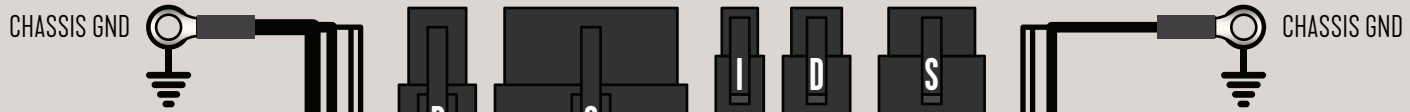

## FRONT GND

GND	16AWG, 0.5m	(-)	DASH/DRL/HEADLIGHT
GND	18AWG, 0.5m	(-)	HORN
GND	22AWG, 0.5m	(-)	LEFT TURN SIGNAL
GND	22AWG, 0.5m	(-)	RIGHT TURN SIGNAL

## POWER

K+	16AWG, 1.25m	(+)	KEY SWITCH POWER IN (LONG)
GND	16AWG, 0.25m	(-)	CHASSIS GROUND IN
S+	16AWG, 0.25m	(+)	SPARE SWITCH POWER OUT (SHORT)
P+	18AWG, 1.25m	(+)	PARK LIGHT SWITCH IN

## OUTPUT

HI	16AWG, 1.25m	(+)	HEADLIGHT HIGH BEAM
F+	18AWG, 0.25m	(+)	PROTECTED POWER
LO	16AWG, 1.25m	(+)	HEADLIGHT LOW BEAM
ENGINE	18AWG, 0.75m	(+)	ENGINE IGNITION POWER
HORN	18AWG, 0.75m	(+)	HORN
STARTER	18AWG, 0.5m	(+)	STARTER SOLENOID / RELAY
TAILLIGHT	18AWG, 0.75m	(+)	TAIL LIGHT MARKER
BRAKELIGHT	18AWG, 0.75m	(+)	BRAKE LIGHT
LEFT TURN	(2) 22AWG, 1.25m, 0.75m	(+)	LEFT TURN SIGNAL LIGHTS (FRONT & REAR)
RIGHT TURN	(2) 22AWG, 1.25m, 0.75m	(+)	RIGHT TURN SIGNAL LIGHTS (FRONT & REAR)

## INPUT

OIL	22AWG, 0.75m	(-)	OIL SWITCH
RUN SENSE	22AWG, 0.75m	(~)	IGNITION COIL TRIGGER
NEUTRAL	22AWG, 0.75m	(-)	NEUTRAL SWITCH
REAR BRAKE	22AWG, 0.75m	(-)	REAR BRAKE SWITCH

## REAR GND

GND	18AWG, 0.5m	(-)	BRAKE/TAIL LIGHT
GND	22AWG, 0.5m	(-)	RIGHT TURN SIGNAL LIGHT
GND	22AWG, 0.5m	(-)	LEFT TURN SIGNAL LIGHT

## HANDLEBAR SWITCH

BUTTON1	22AWG, 1.25m	(-)	BUTTON1 SWITCH
BUTTON2	22AWG, 1.25m	(-)	BUTTON2 SWITCH
BUTTON3	22AWG, 1.25m	(-)	BUTTON3 SWITCH
BUTTON4	22AWG, 1.25m	(-)	BUTTON4 SWITCH
BUTTON5	22AWG, 1.25m	(-)	BUTTON5 SWITCH
BUTTON6	22AWG, 1.25m	(-)	BUTTON6 SWITCH
TAILLIGHT	22AWG, 1.25m	(-)	TAILLIGHT SWITCH
HEADLIGHT	22AWG, 1.25m	(-)	HEADLIGHT SWITCH
CLUTCH	22AWG, 1.25m	(-)	CLUTCH SWITCH
BRAKE	22AWG, 1.25m	(-)	BRAKE SWITCH

## DASH

D+	22AWG, 1.25m	(+)	GAUGE POWER
RIGHT TURN	22AWG, 1.25m	(+)	RIGHT TURN INDICATOR
NEUTRAL	22AWG, 1.25m	(-)	NEUTRAL INDICATOR
LEFT TURN	22AWG, 1.25m	(+)	LEFT TURN INDICATOR
OIL	22AWG, 1.25m	(-)	OIL INDICATOR
HI	22AWG, 1.25m	(+)	HIGH BEAM INDICATOR

# TC3.M Switch Harness

SELF-SUPPLIED SWITCH SET

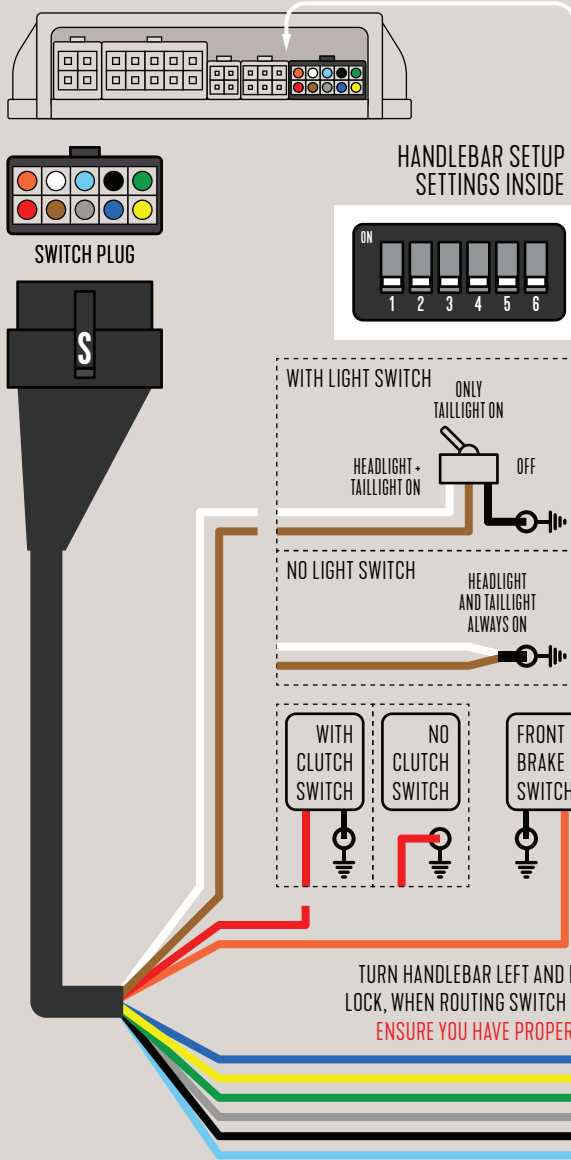

## 1 BUTTON (FORMER TYPE-M)

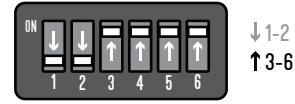

SELF-RETURN (MOMENTARY) ONLY FOR BOTH LEFT AND RIGHT

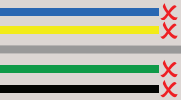

## LEFT HANDLEBAR SWITCH



## RIGHT HANDLEBAR SWITCH



## 2 BUTTON SETTINGS

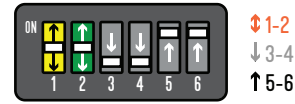

↑ SELF-RETURN (MOMENTARY) UP OR  
↓ SELF-LOCKING (LATCHING) DOWN



### SETTING #1



### SETTING #2

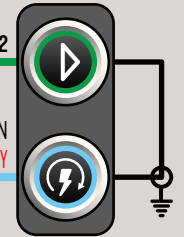

## 3 BUTTON SETTINGS

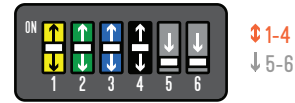

↑ SELF-RETURN (MOMENTARY) UP OR  
↓ SELF-LOCKING (LATCHING) DOWN



### SETTING #1



### SETTING #3



### SETTING #2



### SETTING #4



## STANDARD TYPE SETTINGS

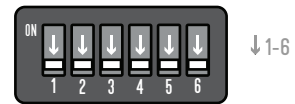

ALL DOWN FOR FACTORY STYLE

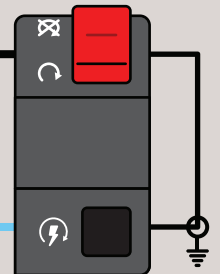
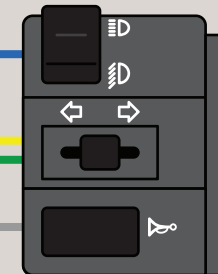

# TC3.M Dash Harness

TURNING DUMMY TO SMART LIGHTS

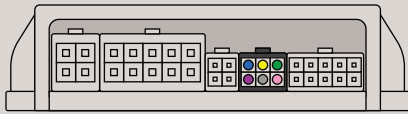

DASH PLUG



D



TURN HANDLEBAR LEFT AND RIGHT, LOCK TO LOCK, WHEN ROUTING DASH CABLES TO ENSURE YOU HAVE PROPER CABLE SLACK.

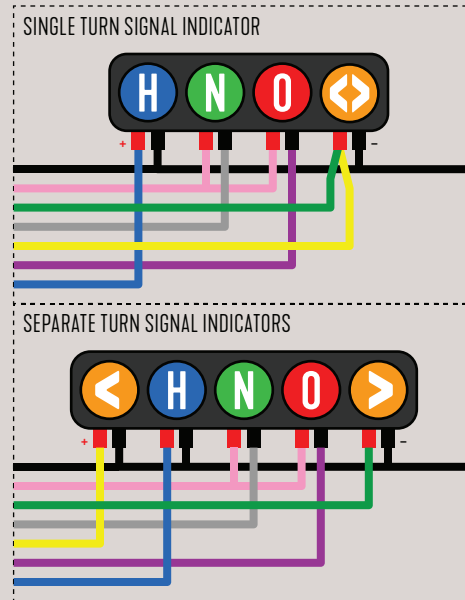
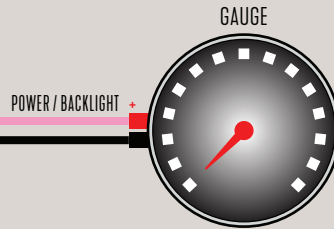

FRONT GND STRAP  
MOUNT ON MAIN FRAME/CHASSIS

16AWG DASH/DRL/HEADLIGHT  
18AWG HORN  
22AWG LEFT TURN SIGNAL LIGHT  
22AWG RIGHT TURN SIGNAL LIGHT

AVOID EXTENDING GROUND WIRES  
KEEP SHORT AS POSSIBLE.

# TC3.M Input Harness

RUN SENSE / NEUTRAL / OIL / R-BRAKE

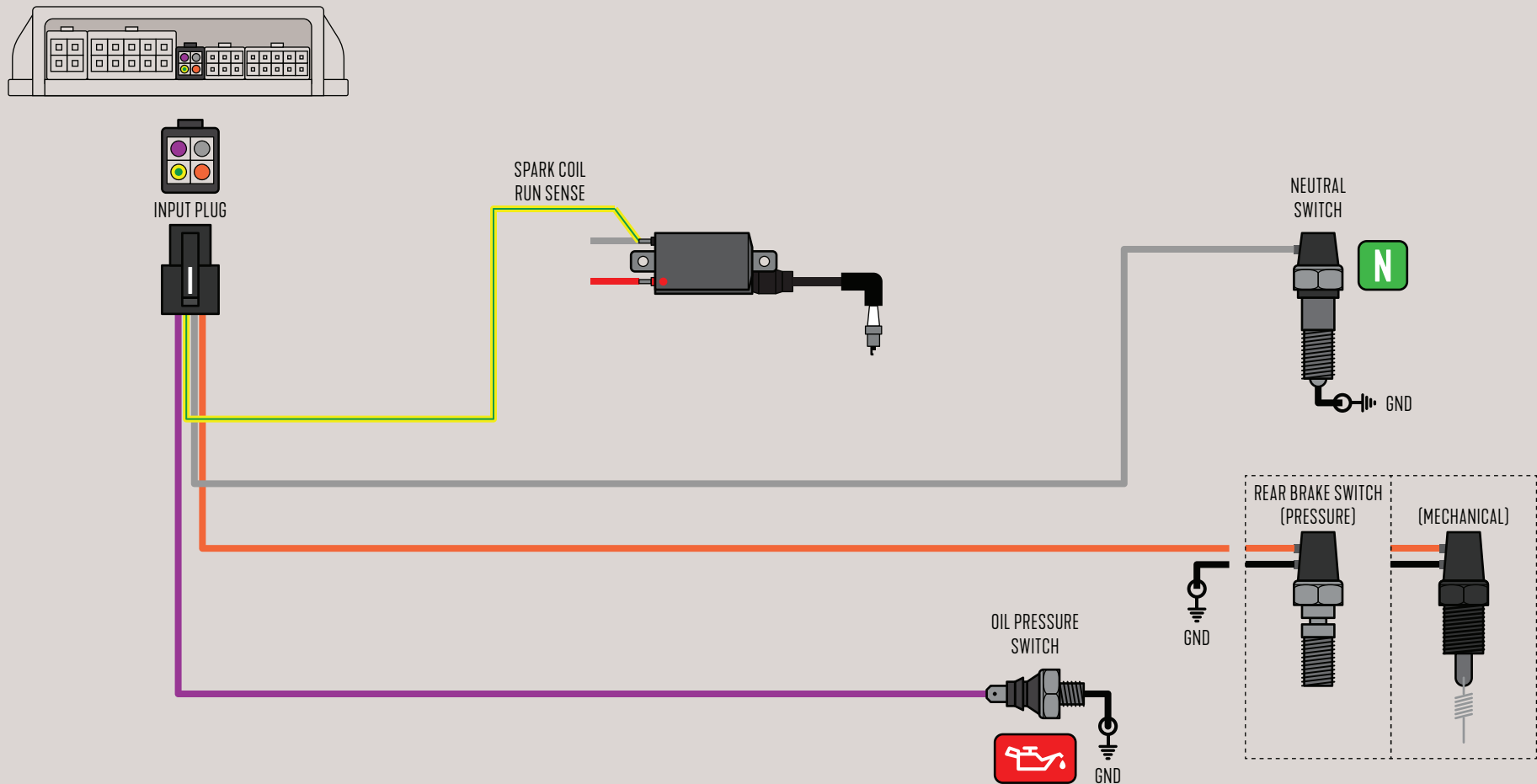

CHECK SWITCHES FOR PROPER FUNCTIONALITY  
CLEAN/REBUILD/REPLACE WHEN NECESSARY

# TC3.M Output Harness

LIGHTING / HORN

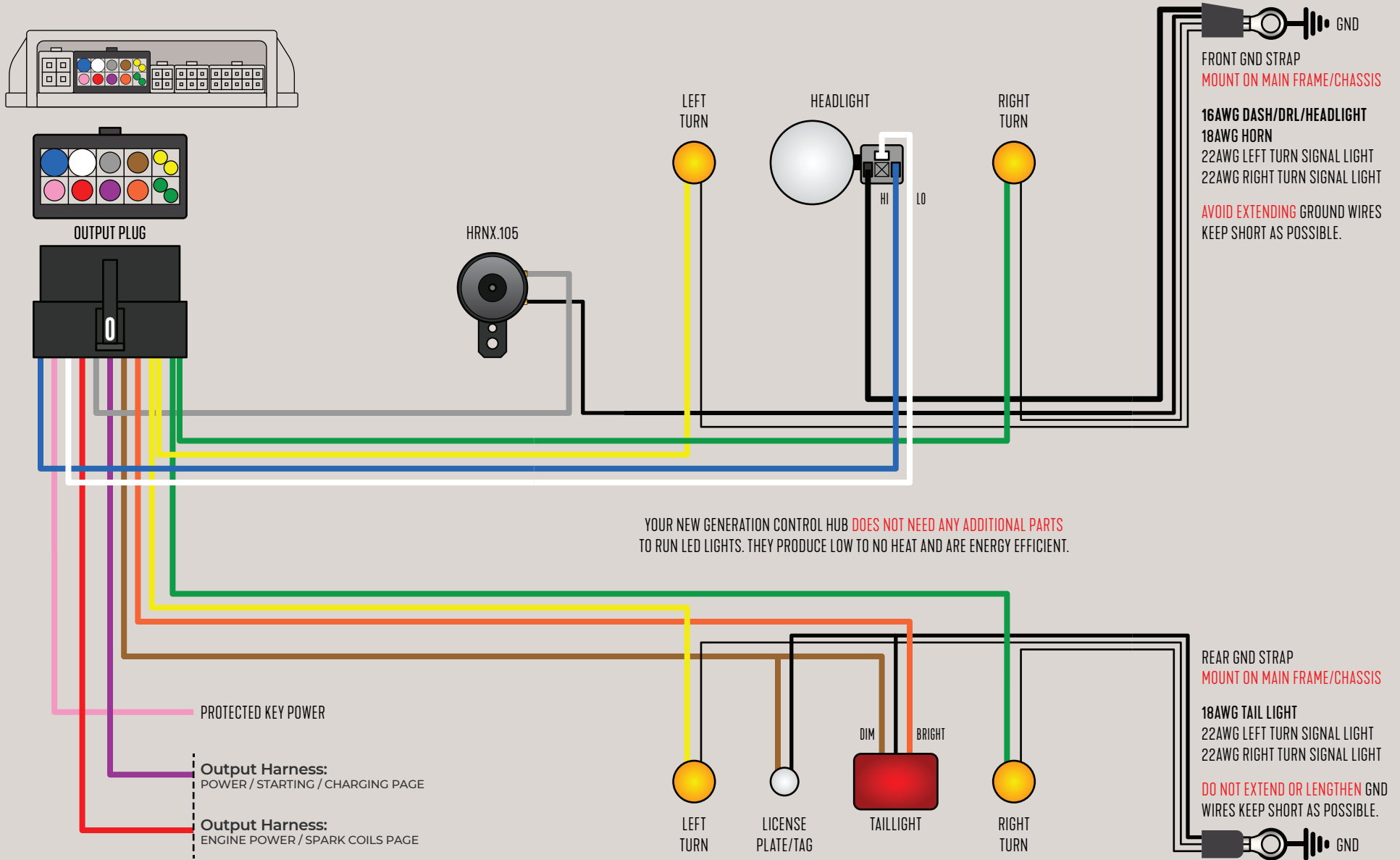

# TC3.M Output Harness

ENGINE POWER / SPARK COILS

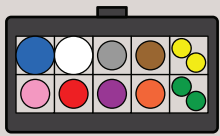
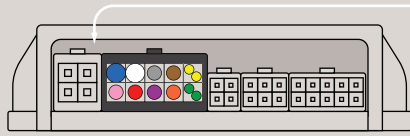

OUTPUT PLUG

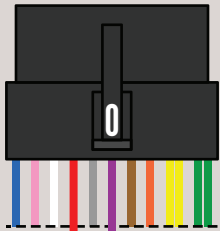

Output Harness:  
LIGHTING / HORN PAGE

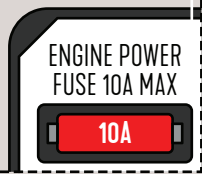

ENGINE POWER  
FUSE 10A MAX

10A

Output Harness:  
POWER / STARTING / CHARGING PAGE

## POINTS BREAKER

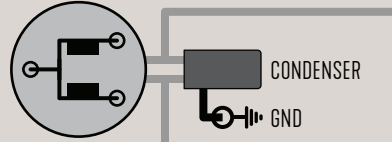

CONDENSER

GND

## CDI (CAPACITOR DISCHARGE IGNITER) / TCI (TRANSISTOR CONTROLLED IGNITER)

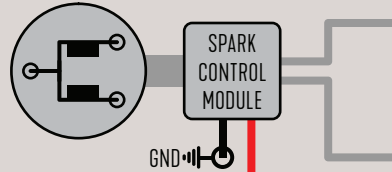
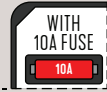

SPARK CONTROL  
MODULE

GND

CONFIRM YOUR  
SPARK COIL  
HAVE 2 WIRES

SPARK COIL PAIRS  
(SINGLE or DUAL)

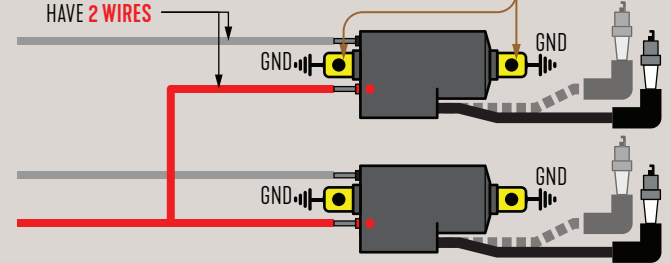

IT IS ABSOLUTELY CRITICAL  
THE COIL **CENTER CORES**  
ARE GROUNDED SOLID,  
DIRECT METAL TO METAL  
ON THE MAIN CHASSIS.

DO NOT ASSUME, CHECK!  
INSPECT, CLEAN AND SECURE SPARK PLUG CAP.  
HARD SPARK PLUG CABLES? INSPECT FOR BREAKS.  
EVEN BRAND NEW PARTS CAN BE DEFECTIVE.

## MAGNETO



REMOVE PRE  
INSTALLED  
FUSE

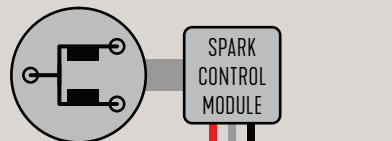

SPARK CONTROL  
MODULE

GND

CONFIRM YOUR SPARK COIL  
ONLY HAVE 1 WIRE

SPARK COIL (SINGLE)

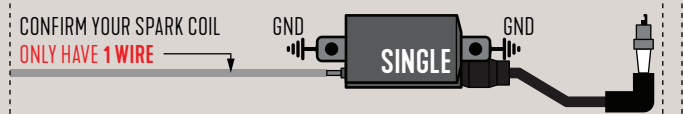

SPARK COIL (DUAL)

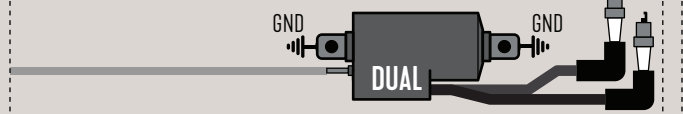

# TC3.M Output Harness

POWER / STARTING / CHARGING

MODERNIZE YOUR CHARGING SYSTEM  
WITH A **DIGITAL TYPE** RECTIFIER+REGULATOR  
FOR SAFER AND MORE EFFICIENT CHARGING SOURCE

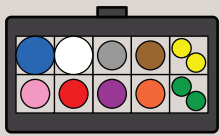
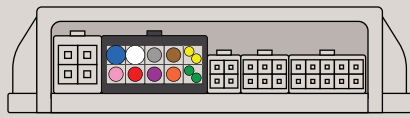

OUTPUT PLUG

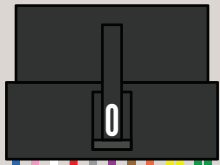

Output Harness:  
LIGHTING / HORN PAGE

Output Harness:  
ENGINE POWER / SPARK COILS PAGE

Power Harness  
PAGE

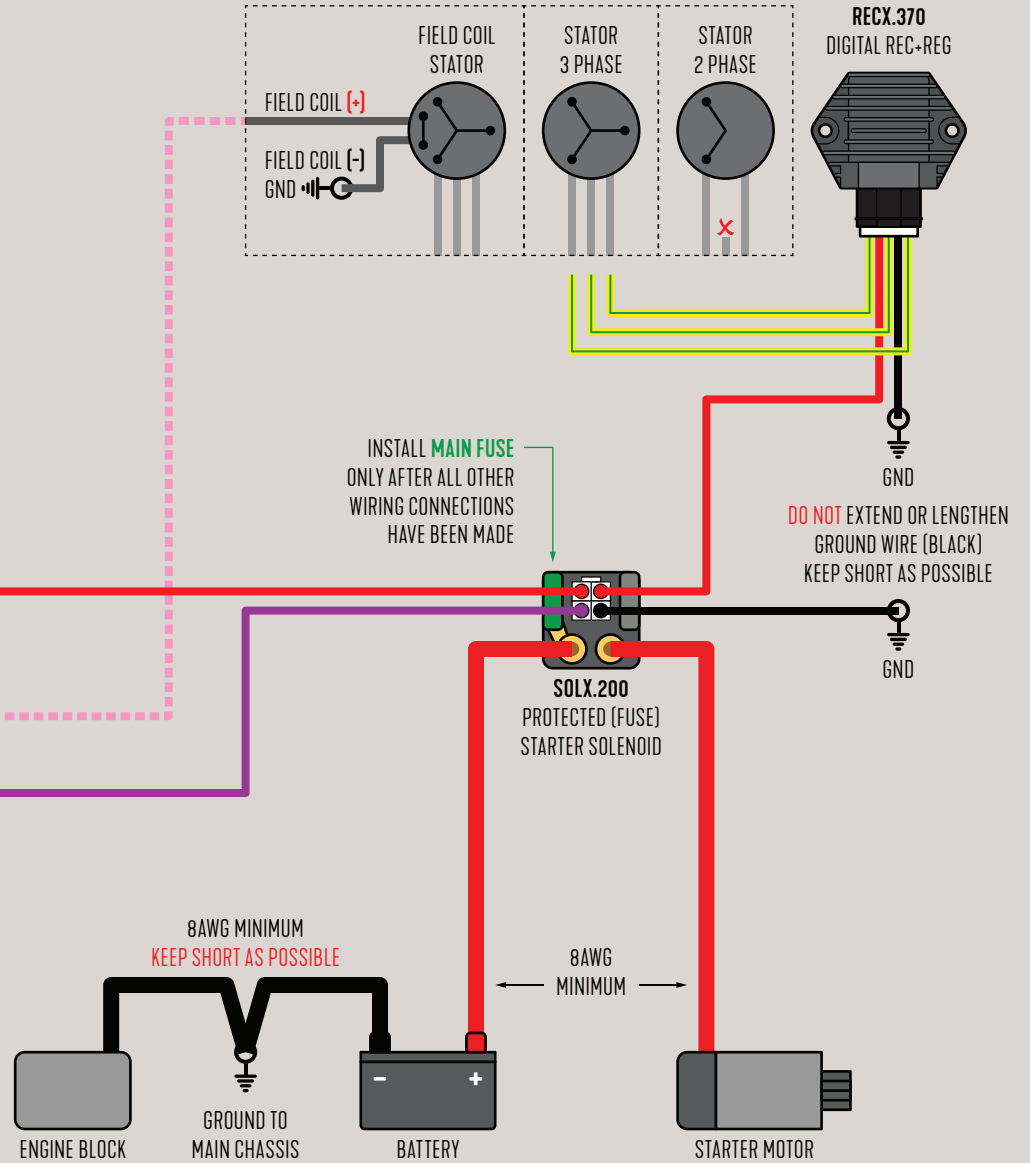



# TC3.M Power Harness

## KEY SWITCH

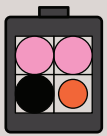
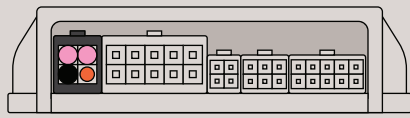

POWER PLUG

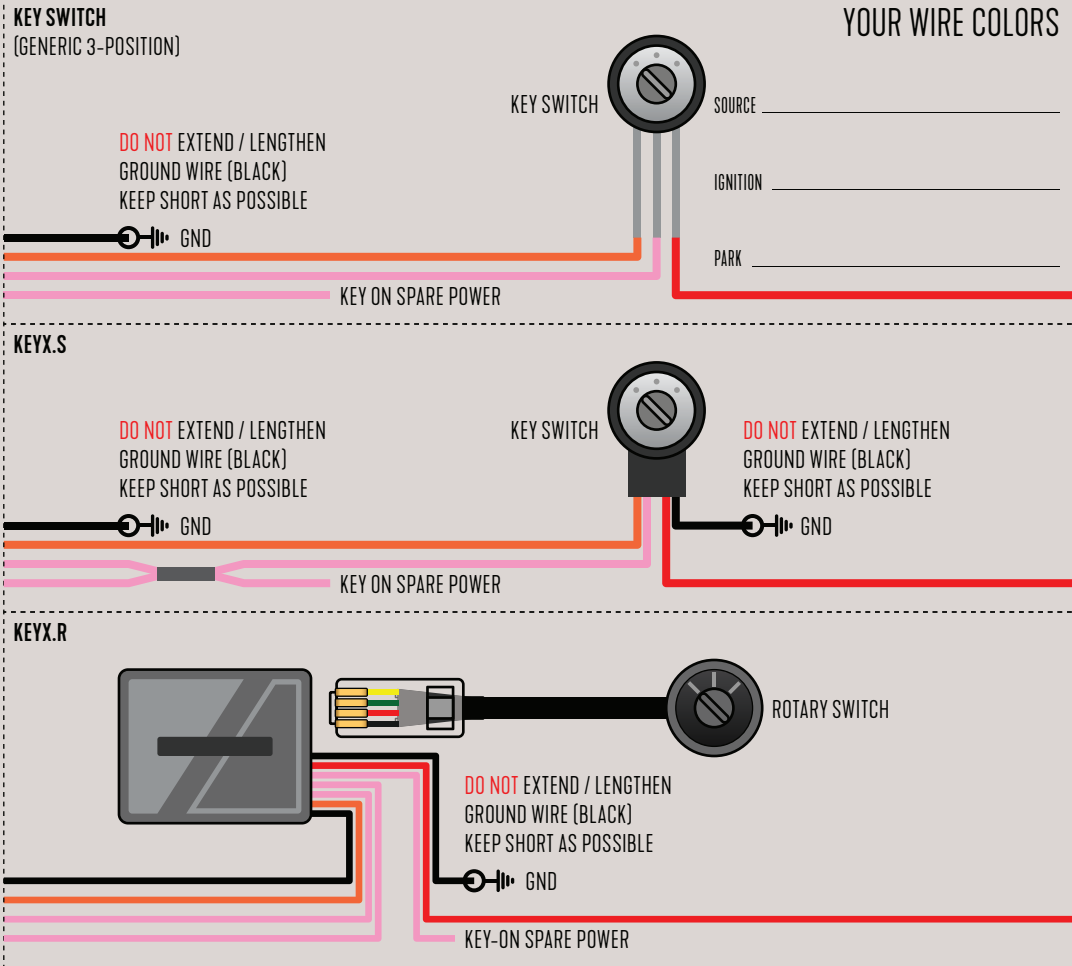

INSTALL MAIN FUSE ONLY AFTER ALL OTHER WIRING CONNECTIONS HAVE BEEN MADE

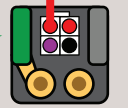

SOLX.200 PROTECTED (FUSE) STARTER SOLENOID